

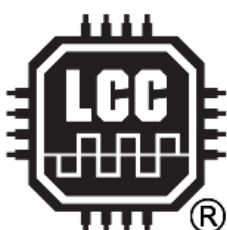

POWER-LCC Module for LCC®/OpenLCB™ SPROG DCC Ltd

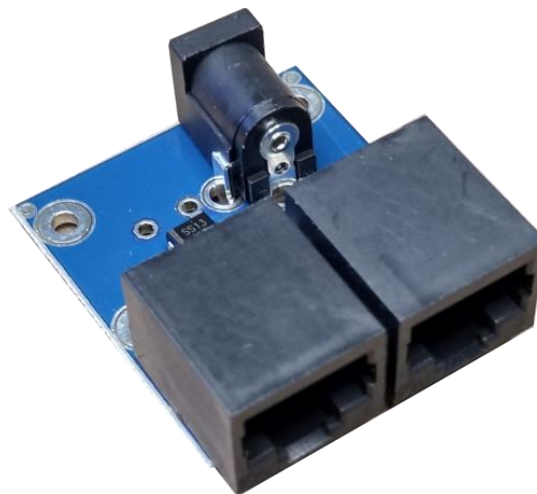

Copyright © January 2024 SPROG DCC Ltd.

This document may be distributed it under the terms of Creative Commons Attribution License (<http://creativecommons.org/licenses/by/3.0/>), version 3.0 or later.

Contact:

SPROG DCC Ltd
Anvil House, Butt Lane
Harbury
Leamington Spa CV33 9JL
United Kingdom
<https://www.sprog-dcc.co.uk>
sprog@sprog-dcc.co.uk

Date	Revision	Comments
January 2024	1	Created
February 2024	1.1	Added isolation diode issue

Unless otherwise notes references in this document to LCC apply equally to OpenLCB, and vice-versa.

LCC® is a registered trademark of the NMRA

OpenLCB™ is a trademark of the OpenLCB Group

Contents

1	Introduction.....	4
2	Links.....	5

1 Introduction

The power LCC allows power to be supplied to an LCC network. It is designed to be used with an external 12V 1 Amp PSU (Power Supply Unit).

2 Connecting the POWER-LCC to the network

The two RJ-45 connectors allow the LCC network to be passed through the USB-LCC whilst supplying power to the network.

The power from the PSU is split into two 500 mA fused supplies, one to each LCC network connector. In a larger network, multiple POWER-LCC may be used to satisfy the power requirements of all the nodes in 500 mA segments.

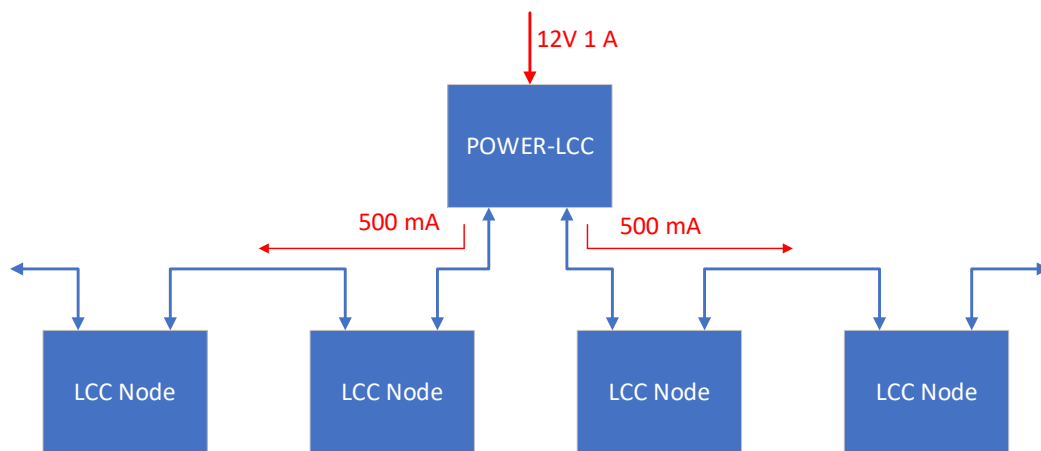

Status LEDs show when power is applied to each segment.

Some LCC nodes may need auxiliary power supplies for high-power loads. Consult the manufacturers' documentation for details.

Nodes should declare what current they take from the LCC network supply, e.g. with a logo on the PCB (Printed Circuit Board). The example below indicates a node that presents a 50 mA load to the network. This information is used to calculate the total current required for each segment of the network.

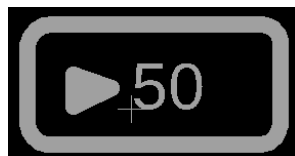

3 Known Issues

3.1 Power Isolation

There is a single isolation diode between the PSU input and the power on the two RJ45 LCC network connectors.

If more than one POWER-LCC is used on a network, issues may be encountered as the power islands created are not isolated.

This will be fixed on a new hardware release.

4 Links

SPROG DCC Ltd website <https://www.sprog-dcc.co.uk> For all our products and support.

SPROG DCC Ltd Official YouTube Channel <https://www.youtube.com/@sprogdcc>

OpenLCB group <https://openlcb.org> The group behind the OpenLCB/LCC standards.

NMRA LCC standards page <https://www.nmra.org/lcc> The LCC standards adopted by the NMRA.

OpenLCB discussion group <https://groups.io/g/openlcb/topics> Discussion of OpenLCB topics, more developer focussed.

The NMRA's LCC user group <https://groups.io/g/layoutcommandcontrol/topics> a good starting point for asking questions of other LCC users.

Book: Introduction to Layout Command Control <https://www.amazon.co.uk/Introduction-Layout-Command-Control-Practical/dp/0988825902> focussed on RR-Cirkit's products but the concepts are applicable to any LCC hardware.